

COMPACT SERIES 880 – 883

ELECTRONIC BENCH AND FLOOR SCALES

EG – legal for trade Class **(III)**



- **Universal**
- **Precise**
- **Robust**
- **Inexpensive**



With arm (optional)

Features

Reliable bench and floor scales for heavy-duty industrial and retail applications and rapid determination of weights and quantities. The various functions offer great versatility and ease of use.

Versions

Order No.	Weighing capability kg	Weighing range kg ¹⁾	Scale interval g	Maximum capacity kg ²⁾	Weighing platform mm	Scale weight kg
880/ 3	0 - 3	0,01 - 3	1,5 kg: 0,5	1,5 kg: 1	350 x 280	5
880/ 6	0 - 6	0,02 - 6	3 kg: 1	3 kg: 2	350 x 280	5
880/ 15	0 - 15	0,04 - 15	6 kg: 2	6 kg: 5	350 x 280	5
881/ 30	0 - 30	0,1 - 30	15 kg: 5	15 kg: 10	500 x 400	14
881/ 60	0 - 60	0,2 - 60	30 kg: 10	30 kg: 20	500 x 400	14
881/ 150	0 - 150	0,4 - 150	60 kg: 20	60 kg: 50	500 x 400	14
882/ 60	0 - 60	0,2 - 60	30 kg: 10	30 kg: 20	650 x 550	39
882/ 150	0 - 150	0,4 - 150	60 kg: 20	60 kg: 50	650 x 550	39
882/ 300	0 - 300	1,0 - 300	150 kg: 50	150 kg: 100	650 x 550	39
882/ 500	0 - 500	2,0 - 500	300 kg: 100	300 kg: 200	650 x 550	39
883/ 150	0 - 150	0,4 - 150	60 kg: 20	60 kg: 50	800 x 600	52
883/ 300	0 - 300	1,0 - 300	150 kg: 50	150 kg: 100	800 x 600	52
883/ 500	0 - 500	2,0 - 500	300 kg: 100	300 kg: 200	800 x 600	52

Indicator 83plus

Housing	Compact, water-jet protected (IP 65) stainless steel (CNS 1.4301) enclosure
Keypad	6 short-stroke keys with pressure point for all functions
Display	7-segment LED display, red, 6-digit, character height 20 mm
Functions	Sum, count, zero, tare, data transfer
Interfaces	2 RS 232/V24 interfaces, 2,400-19,200 bit/s, full duplex, permanent, automatic, according to requirement
Memory	2 tare memories, summing memory

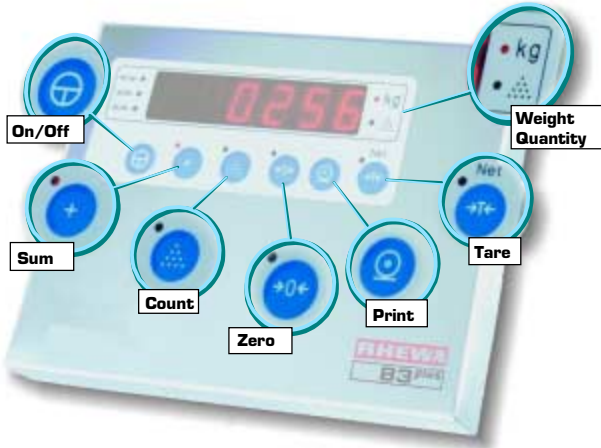

Design type

Direct power feed to strain gauge load cell.

Surface protection

Weighing platform, arms powder-coated. Weighing platform Type 880/881 in stainless steel (CNS 1.4301); Type 882/883 powder-coated. Load cell in anodised aluminium alloy.

Dimensions

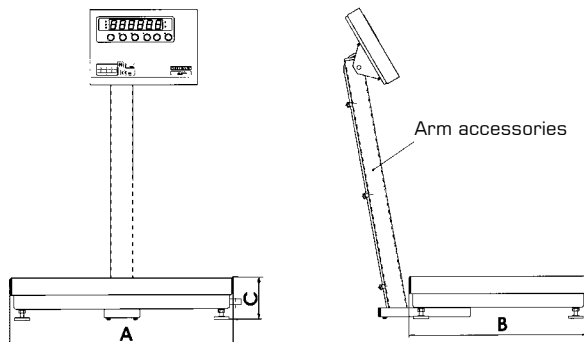

Specifications

Weighing errors	In accordance with European Verification Ordinance and OIML for Class III legal-for-trade appliances
Response time	Approx. 2 s
Operating temperature	-10°C - +40°C
Storage temperature	-20°C - +65°C
Degree of protection	IP 65
Side load	Max 30% of capacity
Measuring cable,	
Type 880/881	2 m, permanent connection
Type 882/883	3 m, permanent connection
Load Cell	R60 approved
AC-adaptor	2 m IP20 cable
Mains voltage	230 VAC -15% +10%

Accessories

Arm, total height approx. 510 mm (Type 880/881)	0212/0
Arm, total height approx. 680 mm (Type 880/881/882)	0212/1
Arm, total height approx. 1000 mm (Type 882/883)	0212/2
Roll printer CBM-270 for thermal paper	0239
Connection costs for printer 0239 (not applicable if installed by customer)	0290
Roll printer holder	0236

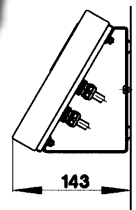

Wall-mounted

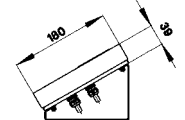

Desktop-mounted

Type	A	B	C
880	350	280	85
881	500	400	85
882	650	550	140
883	800	600	140

¹⁾ Below minimum value for non-legal-for-trade weighings only

²⁾ Where load is evenly distributed